



Speciality Magnetic Components
QUALIFIED to ISO 9001:2008

Hall Effect Current Transformer Panel Mounting Type HT200M



The HT200M is a closed loop Hall Effect Current Transformer which is suitable for Panel Mounting. Provision is made for the primary conductor to be threaded through a single hole. Rated for 200A continuous operation, it offers high accuracy and bandwidth and high electrical isolation. The unit is UL listed, File No. E198118.

Features

- Robust Package
- 7kV Proof Stress
- ± 12 to ± 15 V supplies
- Fast Response
- D.C. Coupled Design

Applications

- Variable Speed Drives
- UPS Systems
- Welding Equipment

Benefits

- No Insertion Loss
- Useable with Bare Primary Conductors
- No Shunt Resistor Required
- No Switching Noise
- Built in Semiconductor Protection
- High Reliability

- Power System Monitoring
- Overcurrent Protection
- Traction Systems

TECHNICAL DATA

Nominal Primary Current	200A
Turns Ratio	2000:1
Nominal Power Supply	$\pm 12V -5\%$ to $\pm 15V +5\%$
Supply Current	25mA per rail + output current
Minimum Burden Resistance	11 Ω
Operating Temperature Range	-10 to +85°C
Storage Temperature Range	-40°C to +90°C

SPECIFICATION

Linearity	0.1% of nominal primary current.
Limit of Linearity (see Note 1)	$\pm 700A$ peak value
Overall Accuracy	0.65% of nominal primary current
Output Offset Current	$< \pm 150\mu A$ at primary current = 0A
Output Offset Current After Overload	$< \pm 250\mu A$ at primary current = 0A
Zero Offset/Temperature	$< 3\mu A/^{\circ}C$
Zero Offset/Supply Variation	$< 5\mu A/V$
Coil resistance	20 Ω at 25°C
Bandwidth	DC to 75kHz at -1dB, DC to 125kHz at -3dB
di/dt following	$> 100A/\mu s$
Delay Time	$< 0.5\mu s$
Proof Stress Voltage	7kV a.c., rms for 1 minute
Creepage Distance	14 mm min
Clearance Distance	14 mm min

GENERAL DATA

Weight	100g
Housing Material	Modified PPO Flammability Rating UL94 V0
Connector	Molex 5046-04/AG
Signal Sense	A positive output is obtained across the burden when current flows in the direction of the arrow.

Note 1: At maximum ambient temperature and supply voltage, the duration of overload currents should not exceed 2 minutes in any 15 minute period

DIMENSIONS

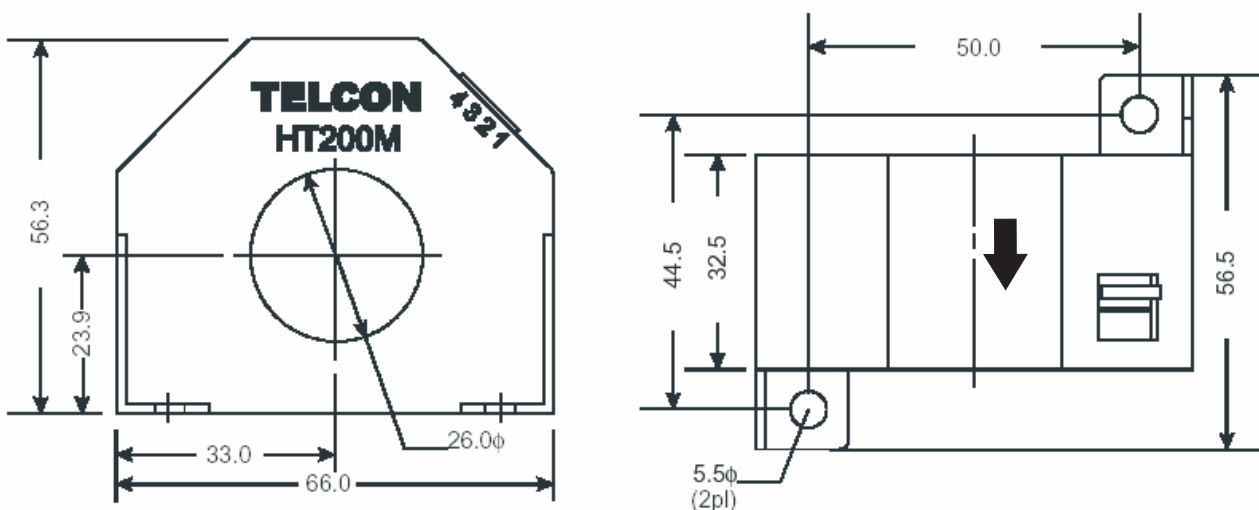

Pin-out	1: +15V	2: O/P
	3: -15V	4: N/C

28.11.00